

Inductive type proximity sensor

UP  Round type  Square type

INSTRUCTION MANUAL

Thank you for purchasing HANYOUNG product.  
Please check whether the product is the exactly same as you ordered.  
Before using the product, please read this instruction manual carefully.  
Please keep this manual where you can view at any time

HANYOUNGNEX CO.,LTD  
1381-3, Juan-Dong, Nam-Gu Incheon, Korea.  
TEL:(82-32)876-4697  
FAX:(82-32)876-4696  
http://www.hynux.net

HEAD OFFICE

INDONESIA FACTORY

PT. HANYOUNG ELECTRONIC INDONESIA  
Jl. cempaka blok F16, No.02 Delta Silicon II  
Cikarang Bekasi Indonesia  
TEL : 62-21-8911-8120~4  
FAX : 62-21-8911-8126

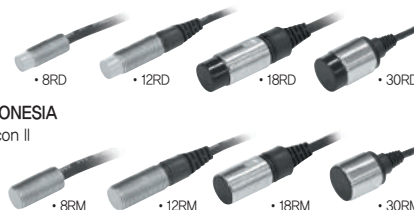

HANYOUNG NUX

Safety information

Before using the product, please read the safety information thoroughly and use it properly.  
Alerts declared in the manual are classified to Danger, Warning and Caution by their criticality

	<b>DANGER</b>	DANGER indicates an imminently hazardous situation which, if not avoided, will result in death or serious injury
	<b>WARNING</b>	WARNING indicates a potentially hazardous situation which, if not avoided, could result in death or serious injury
	<b>CAUTION</b>	CAUTION indicates a potentially hazardous situation which, if not avoided, may result in minor or moderate injury

WARNING

- If the user use the product with methods other than specified by the manufacturer, there may be bodily injuries or property damages.
- If there is a possibility of an accident caused by errors or malfunctions of this product, install external protection circuit to prevent the accident.

CAUTION

- Pay attention that it is possible to damage a proximity sensor by a short circuit when wiring load.
- Wiring to an applicable device shall be certainly connected by using compressing terminals or soldering.
- Do not use PNP type or NPN type indiscriminately.
- Please wire after ensuring whether input conditions are accepted to an applicable device.
- When there is a power or high voltage line close to the cord of the proximity sensor, wire the cord with shielding such as an independent metal conduit to prevent against proximity sensor's damage or malfunction.
- Although the proximity sensor has a surge absorption circuit, if there is any machine that has a large surging one (e.g., a motor, welding machine, etc) near the proximity sensor, connect a varistor, surge absorber, noise filter to a surge generating area.
- Effect of Consumption Current : When AC type of proximity sensor is OFF, the proximity sensor has little consumption current for an operation of the circuit. Because of this fact, the little voltage left in the load may be a cause of load reset defective, so please make sure this voltage is less than the load reset voltage before using.
- In case of a load current is small : When a loaded current of AC type of proximity sensor is less than 5 mA, wire a bleeder resistor with the load in parallel so that make the residual voltage of the proximity sensor be less than the loaded reset voltage.
- Make the ripple content of the rated voltage which supplied into DC (NPN, PNP) type of proximity sensor be less than the maximum ± 10 % of the ripple content.
- In case of using a condenser as a load, wire a current-limiting resistor in series so that set the peak current shall be within the loaded current of the proximity sensor.
- In case of an inductive load (e.g., a motor, relay, magnet, etc), connect the load with surge absorbing diode in parallel.
- Pay attention at a position of attachment, divergence, slack and distortion of a sensing surface or proximity sensor.
- In the place of possibly occurring metal particles, make sure whether a sensing distance is properly working since it can be affected if metal particles stick to the sensing surface.
- Pay attention on using or storing the proximity sensor outdoors.
- Do not use the proximity sensor in an environment with chemical, solvent or corrosive.
- Please avoid as much as possible to put the proximity sensor in hot water or to use them in a place where generates high pressure steam.
- The contents of this manual may be changed without prior notification.
- The maximum cable extension length shall be within 200 m.

Suffix code

Model	Code	Description
UP	<input type="checkbox"/> - <input type="checkbox"/> <input type="checkbox"/> <input type="checkbox"/> <input type="checkbox"/> <input type="checkbox"/> <input type="checkbox"/>	Inductive type proximity sensor
Sensing area size	8	M8
	12	M12
	18	M18
	30	M30
Structure type	RM	Round type shield
	RD	Round type None shield
	RLM	Long round type shield (M8 and M12 are excluded)
	RLD	Long round type None shield (M8 and M12 are excluded)
Sensing distance	*	Sensing distance(mm)
Power supply and output	N	NPN type * Green body, (NO,NC)
	P	PNP type * Purple body, (NO,NC)
	A	A.C 2 wire type(NO : Green, NC : Purple)
	T	D.C 2 wire type(Polarity), (NO : Green, NC : Purple)
	U	D.C 2 wire type(No polarity), (NO : Green, NC : Purple)
Output type	A	Normal open (NO)
	C	Normal close (NC)
Connection structure	*	No indication (Cable type)
	CR	Relay connector type
	C	Connector type

\* M8(Ø8) is only available with the cable type

Specification

■ D.C NPN / PNP type

Model	UP 8RM-1.5 <input type="checkbox"/> <input type="checkbox"/> UP 8RD-2 <input type="checkbox"/> <input type="checkbox"/>	UP 12RM-2 <input type="checkbox"/> <input type="checkbox"/> UP 12RD-4 <input type="checkbox"/> <input type="checkbox"/>	UP 18RM-5 <input type="checkbox"/> <input type="checkbox"/> UP 18RD-8 <input type="checkbox"/> <input type="checkbox"/> UP 18RLM-5 <input type="checkbox"/> <input type="checkbox"/> UP 18RLD-8 <input type="checkbox"/> <input type="checkbox"/>	UP 30RM-10 <input type="checkbox"/> <input type="checkbox"/> UP 30RD-15 <input type="checkbox"/> <input type="checkbox"/> UP 30RLM-10 <input type="checkbox"/> <input type="checkbox"/> UP 30RLD-15 <input type="checkbox"/> <input type="checkbox"/>
Sensing distance	1.5mm, 2mm	2mm, 4mm	5mm, 8mm, 5mm, 8mm	10mm, 15mm, 10mm, 15mm
Setting distance	0-1.2mm, 0-1.6mm	0-1.6mm, 0-3.2mm	0-4mm, 0-6.4mm 0-4mm, 0-6.4mm	0-8mm, 0-12mm 0-8mm, 0-12mm
Response frequency	800 Hz	800, 400 Hz	350, 200, 350, 200 Hz	250, 100, 250, 100 Hz
Standard sensing object (mm)	Iron 8x8x1	Iron 12x12x1	Iron 18x18x1 Iron 25x25x1 Iron 18x18x1 Iron 25x25x1	Iron 30x30x1 Iron 45x45x1 Iron 30x30x1 Iron 45x45x1
Hysteresis	Less than 10 % of sensing distance			
Power supply voltage	12V - 24V d.c (5-35V d.c)			
Control output	Resistive load : 200 mA max			
Residual voltage	1.5 V max			
Current consumption	6 mA max			
Operation indication	Red LED			
Protective circuit	Power reversely connected protective circuit, surge protective circuit and over current protective circuit are built in.			
Ambient temperature	-25 ~ 70 °C (Less than ±10 % of sensing distance at temperature 20 °C)			
Ambient humidity	35 ~ 85 % R.H.			
Degree of protection	IP67 (IEC standard)			
Vibration resistance	10 - 55 Hz (cycle 1 min, double amplitude : 1.5 mm 2 hours for each of X, Y and Z directions)			
Dielectric strength	For 1 min at 2000 V a.c 50/60 Hz (between the recharging part and case)			
Shock resistance	500 % 3 times to each, X, Y and Z directions			
Insulation resistance	50 MΩ min (500 V d.c mega standard)			
Material	CASE : Brass (Chrome plating), Sensing surface : PBT 8R CASE : Stainless, Sensing surface : PBT			

■ D.C 2wire type

Model	UP 8RM-1.5 <input type="checkbox"/> <input type="checkbox"/> UP 8RD-2 <input type="checkbox"/> <input type="checkbox"/>	UP 12RM-2 <input type="checkbox"/> <input type="checkbox"/> UP 12RD-4 <input type="checkbox"/> <input type="checkbox"/>	UP 18RM-5 <input type="checkbox"/> <input type="checkbox"/> UP 18RD-8 <input type="checkbox"/> <input type="checkbox"/> UP 18RLM-5 <input type="checkbox"/> <input type="checkbox"/> UP 18RLD-8 <input type="checkbox"/> <input type="checkbox"/>	UP 30RM-10 <input type="checkbox"/> <input type="checkbox"/> UP 30RD-15 <input type="checkbox"/> <input type="checkbox"/> UP 30RLM-10 <input type="checkbox"/> <input type="checkbox"/> UP 30RLD-15 <input type="checkbox"/> <input type="checkbox"/>
Sensing distance	1.5mm, 2mm	2mm, 4mm	5mm, 8mm	10mm, 15mm, 10mm, 15mm
Setting distance	0-1.2mm, 0-1.6mm	0-1.6mm, 0-3.2mm	0-4mm, 0-6.4mm	0-8mm, 0-12mm 0-8mm, 0-12mm
Response frequency	800 Hz	800, 400 Hz	800, 400 Hz	250, 100, 250, 100 Hz
Standard sensing object (mm)	Iron 8x8x1	Iron 12x12x1	Iron 18x18x1 Iron 25x25x1	Iron 30x30x1 Iron 45x45x1 Iron 30x30x1 Iron 45x45x1
Hysteresis	Less than 10 % of sensing distance			
Power supply voltage	12V-24V d.c (10-30V d.c)			
Control output	Resistive load : 100 mA max			
Residual voltage	T(Polarity) : max 3.5 V, U(No polarity) : 5 V max			
Current consumption	1 mA max			
Operation indication	Red LED			
Protective circuit	surge protective circuit and over current protective circuit are built in.			
Ambient temperature	-25 ~ 70 °C (Less than ±10 % of sensing distance at temperature 20 °C)			
Ambient humidity	35 ~ 85 % R.H.			
Degree of protection	IP67 (IEC standard)			
Vibration resistance	10 - 55 Hz (cycle 1 min, double amplitude : 1.5 mm 2 hours for each of X, Y and Z directions)			
Dielectric strength	For 1 min at 2000 V a.c 50/60 Hz (between the recharging part and case)			
Shock resistance	500 % 3 times to each, X, Y and Z directions			
Insulation resistance	50 MΩ min (500 V d.c mega standard)			
Material	12R, 18R, 30R CASE : Brass (Chrome Plating), Sensing surface : PBT 8R CASE : Stainless, Sensing surface : PBT			

## A.C 2wire Type

Model	UP 12RM-2A □ UP 12RD-4A □	UP 18RM-5A □ UP 18RD-8A □ UP 18RLM-5A □ UP 18RLD-8A □	UP 30RM-10A □ UP 30RD-15A □ UP 30RLM-10A □ UP 30RLD-15A □
Sensing distance	2mm, 4mm	5mm, 8mm, 5mm, 8mm	10mm, 15mm, 10mm, 15mm
Setting distance	0-1.6mm, 0-3.2mm	0-4mm, 0-6.4mm 0-4mm, 0-6.4mm	0-8mm, 0-12mm 0-8mm, 0-12mm
Response frequency	20 Hz		
Standard sensing object (mm)	Iron 12×12×1	Iron 18×18×1 Iron 25×25×1 Iron 18×18×1 Iron 25×25×1	Iron 30×30×1 Iron 45×45×1 Iron 30×30×1 Iron 45×45×1
Hysteresis	Less than 10 % of sensing distance		
Power supply voltage	100V - 240V a.c (90V - 250V a.c)		
Control output	Resistive load : 200 mA max		
Residual voltage	10 V a.c max		
Current consumption	2.2 mA max		
Operation indication	Red LED		
Protective circuit	surge protective circuit built in.		
Ambient temperature	-25 ~ 70 °C (Less than ±10 % of sensing distance at temperature 20 °C)		
Ambient humidity	35 ~ 85 % R.H.		
Degree of protection	IP67 (IEC standard)		
Vibration resistance	10 - 55 Hz (cycle 1 min, double amplitude : 1.5 mm 2 hours for each of X, Y and Z directions)		
Dielectric strength	For 1 min at 2000 V a.c 50/60 Hz (between the recharging part and case)		
Shock resistance	500 % 3 times to each, X, Y and Z directions		
Insulation resistance	50 MΩ min (500 V d.c mega standard)		
Material	CASE : PBT resin		

## Dimension

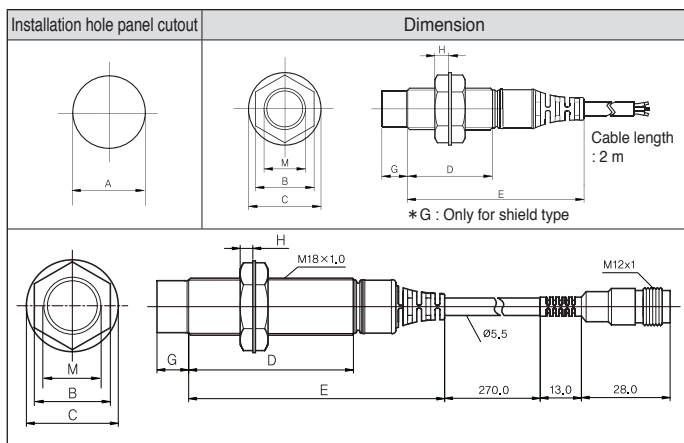

## D.C NPN/PNP/2wire Type

[Unit : mm]

Model	M	A	B	C	D	E	G	H
UP 8RM-1.5 □□	8	9	13	15	33	-	-	3.4
UP 8RD-2 □□	8	9	13	15	29	-	4	3.4
UP 12RM-2 □□	12	13	17	21	32	59	-	3
UP 12RD-4 □□	12	13	17	21	24.5	51.5	7.5	3
UP 18RM-5 □□	18	19	24	29	29	57.8	-	4
UP 18RD-8 □□	18	19	24	29	19	47.8	10	4
UP 18RLM-5 □□	18	19	24	29	62	90.8	-	4
UP 18RLD-8 □□	18	19	24	29	52	80.8	10	4
UP 30RM-10 □□	30	31	35	43	38	66.8	-	5
UP 30RD-15 □□	30	31	35	43	28	56.8	10	5
UP 30RLM-10 □□	30	31	35	43	60	88.8	-	5
UP30RLD-15 □□	30	31	35	43	50	78.8	10	5

## A.C 2wire Type

[Unit : mm]

Model	M	A	B	C	D	E	G	H
UP 12RM-2A □	12	13	17	21	49	76	-	3
UP 12RD-4A □	12	13	17	21	42	68.5	7.5	3
UP 18RM-5A □	18	19	24	29	36	64.8	-	4
UP 18RD-8A □	18	19	24	29	26	54.8	10	4
UP 18RLM-5A □	18	19	24	29	62	90.8	-	4
UP 18RLD-8A □	18	19	24	29	52	80.8	10	4
UP 30RM-10A □	30	31	35	43	38	66.8	-	5
UP 30RD-15A □	30	31	35	43	28	56.8	10	5
UP 30RLM-10A □	30	31	35	43	60	88.8	-	5
UP 30RLD-15A □	30	31	35	43	50	78.8	10	5

## Connection diagram

Type	Connection method	Output state															
D.C open / close		<table border="1"> <thead> <tr> <th></th> <th>NO</th> <th>NC</th> </tr> </thead> <tbody> <tr> <td>Sensing object</td> <td>Yes</td> <td>No</td> </tr> <tr> <td>LOAD [Brown - Black]</td> <td>Run</td> <td>Return</td> </tr> <tr> <td>Output voltage</td> <td>H</td> <td>L</td> </tr> <tr> <td>Operation indicator</td> <td>ON</td> <td>OFF</td> </tr> </tbody> </table>		NO	NC	Sensing object	Yes	No	LOAD [Brown - Black]	Run	Return	Output voltage	H	L	Operation indicator	ON	OFF
			NO	NC													
		Sensing object	Yes	No													
LOAD [Brown - Black]	Run	Return															
Output voltage	H	L															
Operation indicator	ON	OFF															
<table border="1"> <thead> <tr> <th></th> <th>NO</th> <th>NC</th> </tr> </thead> <tbody> <tr> <td>Sensing object</td> <td>Yes</td> <td>No</td> </tr> <tr> <td>LOAD [Brown - Black]</td> <td>Run</td> <td>Return</td> </tr> <tr> <td>Output voltage</td> <td>H</td> <td>L</td> </tr> <tr> <td>Operation indicator</td> <td>ON</td> <td>OFF</td> </tr> </tbody> </table>		NO	NC	Sensing object	Yes	No	LOAD [Brown - Black]	Run	Return	Output voltage	H	L	Operation indicator	ON	OFF		
	NO	NC															
Sensing object	Yes	No															
LOAD [Brown - Black]	Run	Return															
Output voltage	H	L															
Operation indicator	ON	OFF															
<table border="1"> <thead> <tr> <th></th> <th>NO</th> <th>NC</th> </tr> </thead> <tbody> <tr> <td>Sensing object</td> <td>Yes</td> <td>No</td> </tr> <tr> <td>LOAD [Brown - Black]</td> <td>Run</td> <td>Return</td> </tr> <tr> <td>Output voltage</td> <td>H</td> <td>L</td> </tr> <tr> <td>Operation indicator</td> <td>ON</td> <td>OFF</td> </tr> </tbody> </table>		NO	NC	Sensing object	Yes	No	LOAD [Brown - Black]	Run	Return	Output voltage	H	L	Operation indicator	ON	OFF		
	NO	NC															
Sensing object	Yes	No															
LOAD [Brown - Black]	Run	Return															
Output voltage	H	L															
Operation indicator	ON	OFF															
A.C open / close		<table border="1"> <thead> <tr> <th></th> <th>NO</th> <th>NC</th> </tr> </thead> <tbody> <tr> <td>Sensing object</td> <td>Yes</td> <td>No</td> </tr> <tr> <td>LOAD [Brown - Black]</td> <td>Run</td> <td>Return</td> </tr> <tr> <td>Operation indicator</td> <td>ON</td> <td>OFF</td> </tr> </tbody> </table>		NO	NC	Sensing object	Yes	No	LOAD [Brown - Black]	Run	Return	Operation indicator	ON	OFF			
			NO	NC													
		Sensing object	Yes	No													
LOAD [Brown - Black]	Run	Return															
Operation indicator	ON	OFF															
<table border="1"> <thead> <tr> <th></th> <th>NO</th> <th>NC</th> </tr> </thead> <tbody> <tr> <td>Sensing object</td> <td>Yes</td> <td>No</td> </tr> <tr> <td>LOAD [Brown - Black]</td> <td>Run</td> <td>Return</td> </tr> <tr> <td>Operation indicator</td> <td>ON</td> <td>OFF</td> </tr> </tbody> </table>		NO	NC	Sensing object	Yes	No	LOAD [Brown - Black]	Run	Return	Operation indicator	ON	OFF					
	NO	NC															
Sensing object	Yes	No															
LOAD [Brown - Black]	Run	Return															
Operation indicator	ON	OFF															
<table border="1"> <thead> <tr> <th></th> <th>NO</th> <th>NC</th> </tr> </thead> <tbody> <tr> <td>Sensing object</td> <td>Yes</td> <td>No</td> </tr> <tr> <td>LOAD [Brown - Black]</td> <td>Run</td> <td>Return</td> </tr> <tr> <td>Operation indicator</td> <td>ON</td> <td>OFF</td> </tr> </tbody> </table>		NO	NC	Sensing object	Yes	No	LOAD [Brown - Black]	Run	Return	Operation indicator	ON	OFF					
	NO	NC															
Sensing object	Yes	No															
LOAD [Brown - Black]	Run	Return															
Operation indicator	ON	OFF															

## Mutual interference and effects of surrounding metals

- When attaching more than 1 proximity sensors in parallel direction or facing each other, it can cause the malfunction. When there are metals around the proximity sensor, it can cause malfunctions such as abnormal return due to the existence of metals around the proximity sensor. In order to avoid the malfunction which caused by surrounding metals, please install it with sufficient gap from each other. (Wider than the values written in below chart)

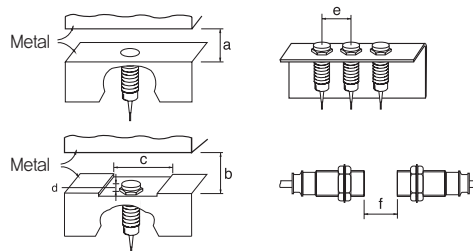

[Unit : mm]

List	Model	UP8RM-1.5	UP8RD-2	UP12RM-2	UP12RD-4	UP18RM-5	UP18RD-8	UP30RM-10	UP30RD-15
a		4.5	-	6	-	15	-	30	-
b		-	6	-	12	-	24	-	54
c		8	24	12	36	18	54	30	90
d		0	8	0	11	0	14	0	15
e		16	24	24	36	36	54	60	90
f		9	12	12	24	30	48	60	60

## How to set distance

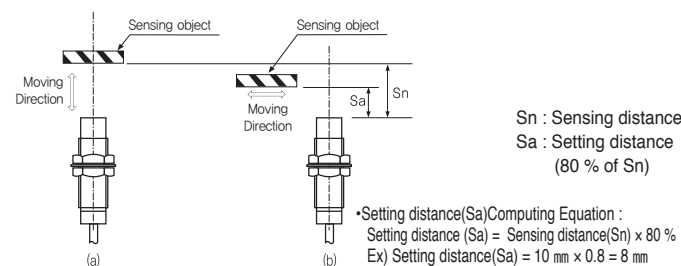

- When a proximity sensor is operating as a sensing object is approaching, a distance between the sensing surface and the sensing object is the operating distance of the proximity sensor.
- After measuring a maximum value of a perpendicular direction of a sensing object, install it within 80 %.
- When testing a sensing distance of a proximity sensor, a standard sensing object was used so a sensing distance can be varied by its shape, form or material. Please, consider these facts.

Inductive type proximity sensor

UP  Round  Square type

INSTRUCTION MANUAL

Thank you for purchasing HANYOUNG product.  
Please check whether the product is the exactly same as you ordered.  
Before using the product, please read this instruction manual carefully.  
Please keep this manual where you can view at any time

HEAD OFFICE

HANYOUNG NUX CO.,LTD  
1381-3, Juan-Dong, Nam-Gu Incheon, Korea.  
TEL:(82-32)876-4697  
FAX:(82-32)876-4696  
http://www.hynux.net

INDONESIA FACTORY

PT. HANYOUNG ELECTRONIC INDONESIA  
JL.CEMPAKA BLOK F 16 NO.02 DELTA  
SILICON II INDUSTRIAL PARK  
LIPPO CIKARANG CICAU, CIKARANG  
PUSAT BEKASI 17550 INDONESIA  
TEL : 62-21-8911-8120~4  
FAX : 62-21-8911-8126



Safety information

Before using the product, please read the safety information thoroughly and use it properly. Alerts declared in the manual are classified to Danger, Warning and Caution by their criticality

<b>DANGER</b>	DANGER indicates an imminently hazardous situation which, if not avoided, will result in death or serious injury
<b>WARNING</b>	WARNING indicates a potentially hazardous situation which, if not avoided, could result in death or serious injury
<b>CAUTION</b>	CAUTION indicates a potentially hazardous situation which, if not avoided, may result in minor or moderate injury

**Warning**

- If the user use the product with methods other than specified by the manufacturer, there may be bodily injuries or property damages.
- If there is a possibility of an accident caused by errors or malfunctions of this product, install external protection circuit to prevent the accident.

**Caution**

- Pay attention that it is possible to damage a proximity sensor by a short circuit when wiring load.
- Wiring to an applicable device shall be certainly connected by using compressing terminals or soldering.
- Do not use PNP type or NPN type indiscriminately.
- Please wire after ensuring whether input conditions are accepted to an applicable device.
- When there is a power or high voltage line close to the cord of the proximity sensor, wire the cord with shielding such as an independent metal conduit to prevent against proximity sensor's damage or malfunction.
- Although the proximity sensor has a surge absorption circuit, if there is any machine that has a large surging one (e.g., a motor, welding machine, etc) near the proximity sensor, connect a varistor, surge absorber, noise filter to a surge generating area.
- Effect of Consumption Current : When AC type of proximity sensor is OFF, the proximity sensor has little consumption current for an operation of the circuit. Because of this fact, the little voltage left in the load may be a cause of load reset defective, so please make sure this voltage is less than the load reset voltage before using.
- In case of a load current is small : When a loaded current of AC type of proximity sensor is less than 5 mA, wire a bleeder resistor with the load in parallel so that make the residual voltage of the proximity sensor be less than the loaded reset voltage.
- Make the ripple content of the rated voltage which supplied into DC (NPN, PNP) type of proximity sensor be less than the maximum  $\pm 10\%$  of the ripple content.
- In case of using a condenser as a load, wire a current-limiting resistor in series so that set the peak current shall be within the loaded current of the proximity sensor.
- In case of an inductive load (e.g., a motor, relay, magnet, etc), connect the load with surge absorbing diode in parallel.

Suffix code

Model	Code	Information
UP	<input type="checkbox"/> S- <input type="checkbox"/> <input type="checkbox"/> <input type="checkbox"/> <input type="checkbox"/> <input type="checkbox"/> <input type="checkbox"/>	Inductive type proximity sensor
Sensing area size	8	8 X 8 mm
	12	12 X 12 mm
	18	18 X 18 mm
	25	25 X 25 mm
	30	30 X 30 mm
Structure type	S	Square type
	F	Flat type
Sensing distance	2	2 mm (Only with UP8S-2)
	4	4 mm (Only with UP12S-4)
	5	5 mm (Only with UP18S-5, UP25S-5)
	8	8 mm (Only with UP18S-8, UP25S-8, UP25F-8)
	10	10 mm (Only with UP30S-10)
	12	12 mm (Only with UP25S-12)
	15	15 mm (Only with UP30S-15)
Power Supply and Output type	N	DC NPN type
	P	DC PNP type
	A	AC 2 wire type (But, UP8S, UP12S, UP18S is excluded)
	T	DC 2 wire type (Polarity)
	U	DC 2 wire type (No polarity) (But, UP8S is excluded)
Output type	A	Normal Open (N.O)
	C	Normal Close (N.C)
Sensing direction	-	No indication (Detect front side)
	U	Detect upper side (Only available with the square type UP12S, UP18S)
Connection structure	-	No indication (Cable type)
	CR	Relay connector type

- Pay attention at a position of attachment, divergence, slack and distortion of a sensing surface or proximity sensor.
- In the place of possibly occurring metal particles, make sure whether a sensing distance is properly working since it can be affected if metal particles stick to the sensing surface.
- Pay attention on using or storing the proximity sensor outdoors.
- Do not use the proximity sensor in an environment with chemical, solvent or corrosive.
- Please avoid as much as possible to put the proximity sensor in hot water or to use them in a place where generates high pressure steam.
- The contents of this manual may be changed without prior notification.
- The maximum cable extension length shall be within 200 m.

Specification

■ DC 3 wire type (NPN/PNP)

Model	UP8S-2□□	UP12S-4□□	UP 18S-5□□ UP 18S-8□□	UP 25S-5□□ UP 25S-8□□ UP 25S-12□□	UP30S-10□□ UP30S-15□□	UP 40S-20□□	UP 25F-8□□
Sensing distance	2 mm	4 mm	5 mm, 8 mm	5mm, 8mm, 12mm	10 mm, 15 mm	20 mm	8 mm
Setting distance	0 - 1.6 mm	0 - 3.2 mm	0 - 4 mm, 0 - 6.4 mm	0-4mm, 0-6.4mm, 0-9.6mm	0 - 8 mm, 0 - 12 mm	0 - 16 mm	0 - 6.4 mm
Response frequency	800 Hz	800 Hz	800 Hz	350, 250, 200 Hz	250, 100 Hz	100 Hz	200 Hz
Standard sensing object (mm)	Iron8×8×1	Iron12×12×1	Iron18×18×1 Iron25×25×1	Iron25×25×1 Iron25×25×1 Iron35×35×1	Iron30×30×1 Iron45×45×1	Iron60×60×1	Iron25×25×1
Hysteresis	Less than 10 % of sensing distance						
Power supply voltage	12 - 24 V d.c (5 - 35 V d.c)						
Control output	Resistive load : 200 mA max.						
Residual voltage	1.5 V max						
Current consumption	6 mA max						
Operation indication	Red LED						
Protective circuit	Power reversely connected protective circuit, surge protective circuit and over current protective circuit are built in.						
Ambient temperature	-25 ~ 70 °C (Less than $\pm 10\%$ of sensing distance at temperature 20 °C)						
Ambient humidity	35 ~ 85 % R,H						
Degree of protection	IP67 (IEC standard)						
Vibration resistance	10 - 55 Hz (cycle 1 min, double amplitude : 1.5 mm 2 hours for each of X, Y and Z directions)						
Dielectric strength	For 1 min at 2000 V a.c 50/60 Hz (between the recharging part and case)						
Shock resistance	500 % 3 times to each, X, Y and Z directions						
Insulation resistance	50 MΩ min (500 V d.c mega standard)						
Material	CASE : PBT resin						

■ DC 2 wire type

Model	UP8S-2□□	UP12S-4□□	UP 18S-5□□ UP 18S-8□□	UP 25S-5□□ UP 25S-8□□ UP 25S-12□□	UP30S-10□□ UP30S-15□□	UP 40S-20□□	UP 25F-8□□
Sensing distance	2 mm	4 mm	5 mm, 8 mm	5mm, 8mm, 12mm	10 mm, 15 mm	20 mm	8 mm
Setting distance	0 - 1.6 mm	0 - 3.2 mm	0 - 4 mm, 0 - 6.4 mm	0-4mm, 0-6.4mm, 0-9.6mm	0 - 8 mm, 0 - 12 mm	0 - 16 mm	0 - 6.4 mm
Response frequency	800 Hz	500 Hz	500, 300 Hz	350, 250, 200 Hz	250, 100 Hz	100 Hz	200 Hz
Standard sensing object (mm)	Iron8×8×1	Iron12×12×1	Iron18×18×1 Iron25×25×1	Iron25×25×1 Iron25×25×1 Iron35×35×1	Iron30×30×1 Iron45×45×1	Iron60×60×1	Iron25×25×1
Hysteresis	Less than 10 % of sensing distance						
Power supply voltage	12 - 24 V d.c (10 - 30 V d.c)						
Control output	Resistive load : 100 mA max.						
Residual voltage	T (Polarity) : 3.5 V max, U (No polarity) : 5 V max						
Leakage current	1 mA max						
Operation indication	Red LED						
Protective circuit	surge protective circuit and over current protective circuit are built in.						
Ambient temperature	-25 ~ 70 °C (Less than $\pm 10\%$ of sensing distance at temperature 20 °C)						
Ambient humidity	35 ~ 85 % R,H						
Degree of protection	IP67 (IEC standard)						
Vibration resistance	10 - 55 Hz (cycle 1 min, double amplitude : 1.5 mm 2 hours for each of X, Y and Z directions)						
Dielectric strength	For 1 min at 2000 V a.c 50/60 Hz (between the recharging part and case)						
Shock resistance	500 % 3 times to each, X, Y and Z directions						
Insulation resistance	50 MΩ min (500 V d.c mega standard)						
Material	CASE : PBT resin						

## AC 2 wire type

Model	UP 25S-5A□ UP 25S-8A□	UP 30S-10A□ UP 30S-15A□	UP 40S-20A□	UP 25F-8A□
Sensing distance	5 mm, 8 mm	10 mm, 15 mm	20 mm	8 mm
Setting distance	0 - 4 mm, 0 - 6.4 mm	0 - 8 mm, 0 - 12 mm	0 - 16 mm	0 - 6.4 mm
Response frequency	20 Hz			
Standard sensing object (mm)	Iron 25×25×1 Iron 30×30×1	Iron 40×40×1 Iron 50×50×1	Iron 60×60×1	Iron 25×25×1
Hysteresis	Less than 10 % of sensing distance			
Power supply voltage	100 - 240 V a.c (90 - 250 V a.c)			
Control output	Resistive load : 200 mA max.			
Residual voltage	10 V a.c max			
Leakage current	2.2 mA max			
Operation indication	Red LED			
Protective circuit	surge protective circuit built in.			
Ambient temperature	-25 ~ 70 °C (Less than ±10 % of sensing distance at temperature 20 °C)			
Ambient humidity	35 ~ 85 % R.H			
Degree of protection	IP67 (IEC standard)			
Vibration resistance	10 - 55 Hz (cycle 1 min, double amplitude : 1.5 mm 2 hours for each of X, Y and Z directions)			
Dielectric strength	For 1 min at 2000 V a.c 50/60 Hz (between the recharging part and case)			
Shock resistance	500 % 3 times to each, X, Y and Z directions			
Insulation resistance	50 MΩ min (500 V d.c mega standard)			
Material	CASE : PBT resin			

## Dimension

[Unit : mm]

Model	Installation hole panel cutout	Dimension
UP8S		
UP12S		
UP18S UP25S UP30S UP40S		

Model	Bolt size	A	B	C	D	E	F	G	H
UP8S	None	8	8	8	8	7.4	0.6	28	2
UP12S	None	15.1	15	12	12	11	1	45	14.5
UP18S	M3X20	11	31.4	18	18	14	0.5	36	15
UP25S	M4X22	18	36.3	25	25	17.2	1	39.5	15
UP30S	M4X30	22	49.3	30	30	21	0.8	53.5	16.5
UP40S	M5X40	29	47.8	40	40	25.5	1	53.3	16.5

## Supporter

UP8S series	
UP12S series	
UP18S series	
UP25S series	
UP30S series	
UP40S series	
UP25F series	

## Connection diagram

Type	Connection method	Output state															
D.C open / close		<table border="1"> <thead> <tr> <th></th> <th>NO</th> <th>NC</th> </tr> </thead> <tbody> <tr> <td>Sensing object</td> <td>Yes</td> <td>No</td> </tr> <tr> <td>LOAD [Brown - Black]</td> <td>Run</td> <td>Return</td> </tr> <tr> <td>Output voltage</td> <td>H</td> <td>L</td> </tr> <tr> <td>Operation indicator</td> <td>ON</td> <td>OFF</td> </tr> </tbody> </table>		NO	NC	Sensing object	Yes	No	LOAD [Brown - Black]	Run	Return	Output voltage	H	L	Operation indicator	ON	OFF
			NO	NC													
		Sensing object	Yes	No													
LOAD [Brown - Black]	Run	Return															
Output voltage	H	L															
Operation indicator	ON	OFF															
<table border="1"> <thead> <tr> <th></th> <th>NO</th> <th>NC</th> </tr> </thead> <tbody> <tr> <td>Sensing object</td> <td>Yes</td> <td>No</td> </tr> <tr> <td>LOAD [Brown - Black]</td> <td>Run</td> <td>Return</td> </tr> <tr> <td>Output voltage</td> <td>H</td> <td>L</td> </tr> <tr> <td>Operation indicator</td> <td>ON</td> <td>OFF</td> </tr> </tbody> </table>		NO	NC	Sensing object	Yes	No	LOAD [Brown - Black]	Run	Return	Output voltage	H	L	Operation indicator	ON	OFF		
	NO	NC															
Sensing object	Yes	No															
LOAD [Brown - Black]	Run	Return															
Output voltage	H	L															
Operation indicator	ON	OFF															
<table border="1"> <thead> <tr> <th></th> <th>NO</th> <th>NC</th> </tr> </thead> <tbody> <tr> <td>Sensing object</td> <td>Yes</td> <td>No</td> </tr> <tr> <td>LOAD [Brown - Black]</td> <td>Run</td> <td>Return</td> </tr> <tr> <td>Operation indicator</td> <td>ON</td> <td>OFF</td> </tr> </tbody> </table>		NO	NC	Sensing object	Yes	No	LOAD [Brown - Black]	Run	Return	Operation indicator	ON	OFF					
	NO	NC															
Sensing object	Yes	No															
LOAD [Brown - Black]	Run	Return															
Operation indicator	ON	OFF															
AC open / close		<table border="1"> <thead> <tr> <th></th> <th>NO</th> <th>NC</th> </tr> </thead> <tbody> <tr> <td>Sensing object</td> <td>Yes</td> <td>No</td> </tr> <tr> <td>LOAD [Brown - Black]</td> <td>Run</td> <td>Return</td> </tr> <tr> <td>Operation indicator</td> <td>ON</td> <td>OFF</td> </tr> </tbody> </table>		NO	NC	Sensing object	Yes	No	LOAD [Brown - Black]	Run	Return	Operation indicator	ON	OFF			
	NO	NC															
Sensing object	Yes	No															
LOAD [Brown - Black]	Run	Return															
Operation indicator	ON	OFF															

## How to set distance

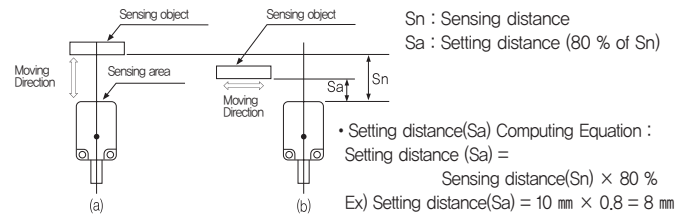

- When a proximity sensor is operating as a sensing object is approaching, a distance between the sensing surface and the sensing object is the operating distance of the proximity sensor.
- After measuring a maximum value of a perpendicular direction of a sensing object, install it within 80 %.
- When testing a sensing distance of a proximity sensor, a standard sensing object was used so a sensing distance can be varied by its shape, form or material. Please, consider these facts.

## How to use differential wave method

- In case of attaching proximity sensors, malfunction can be occurred by mutual interference when the proximity sensors are closely attached. Therefore, please use proximity sensor of Differential Wave Type like the picture shown in the right. Differential Wave Type is only available in Square Type of 18 or 25.

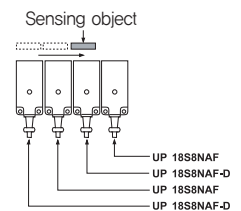

## Mutual interference and effects of surrounding metals

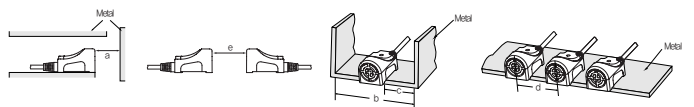

[Unit : mm]

Model	UP 8S	UP 12S	UP 18S	UP 18S	UP 25S	UP 25S	UP 25S	UP 30S	UP 30S	UP 40S
List	-2□□	-4□□	-5□□	-8□□	-5□□	-8□□	-12□□	-10□□	-15□□	-20□□
a	6	12	15	24	15	24	36	30	45	60
b	24	36	-	54	-	-	75	-	90	-
c	8	12	18	18	25	25	25	30	30	40
d	16	24	36	36	50	50	50	60	60	80
e	12	24	30	48	30	48	72	60	90	120